



3+



12



1,3m



1 = 2,58m 2 = 2,4m 3 = 3m



Handicap moteur

Handicap sensoriel

Handicap mental

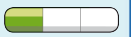
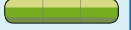
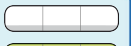

Fonctions ludiques : 7

fabuler



x1

se rencontrer



x2

manipuler



x1

stimulation tactile



x1

grimper



x2

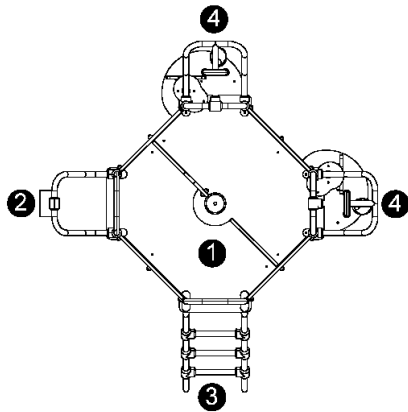

- ① Plate-forme Sahari
- ② Mât cocotier
- ③ Echelle inclinée
- ④ Jeu de sable

Installation de l'équipement

Zone d'impact : Surface de sol minimale requise

- Zone d'impact
- Espace libre

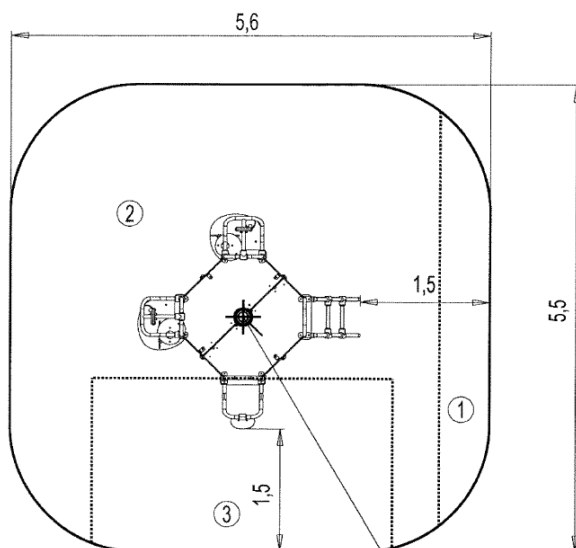

△ 0 Point de Référence
Setting Out Point
Punto de referencia
Bezugspunkt

1	0,60m	2,5m ²
2	1,17m	20m ²
3	1,3m	7,5m ²

2

10h30

0.2m³

29m²

299kg

35kg

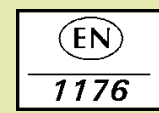

2012-10-09