



3+



10



1,3m



1 = 4,2m 2 = 2,6m 3 = 3m



Handicap moteur

Handicap sensoriel

Handicap mental

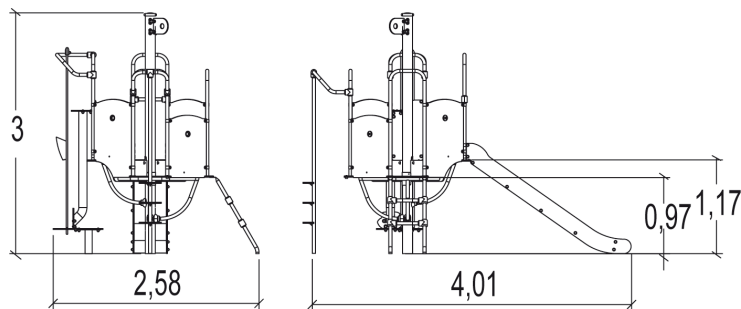
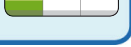
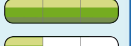
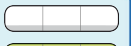

Fonctions ludiques : 8

fabuler



x1

glisser



x1

se rencontrer



x2

manipuler



x1

stimulation tactile



x1

grimper



x2

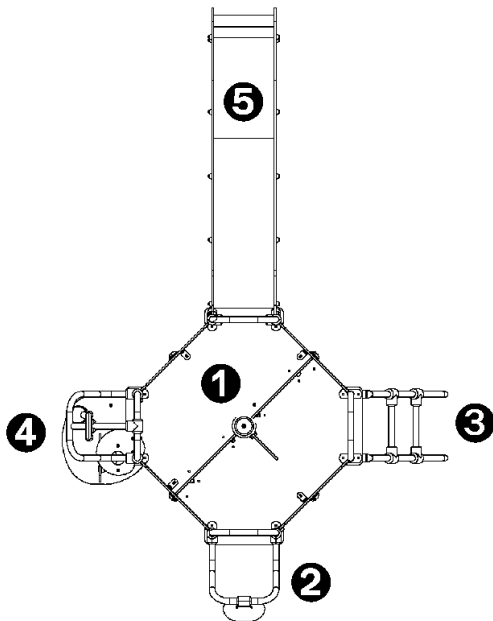

- ❶ Plate-forme Sahari
- ❷ Mât cocotier
- ❸ Echelle inclinée
- ❹ Jeu de sable
- ❺ Toboggan

Installation de l'équipement

Zone d'impact : Surface de sol minimale requise

- Zone d'impact
- Espace libre

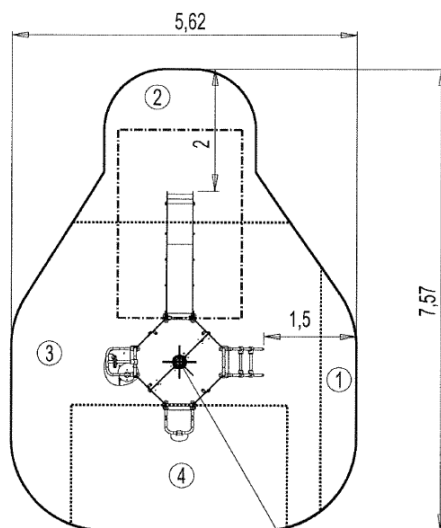

0 Point de Référence
Setting Out Point
Punto de referencia
Bezugspunkt

1	0,6m	1,5m ²
2	1m	6,5m ²
3	1,17m	17m ²
4	1,3m	7,5m ²



2



11h00



0.3m³



32.5m²



295kg



35kg

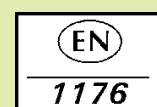

Proludic

2012-10-09