 1=1.5m 2=1.4m 3=3.4m

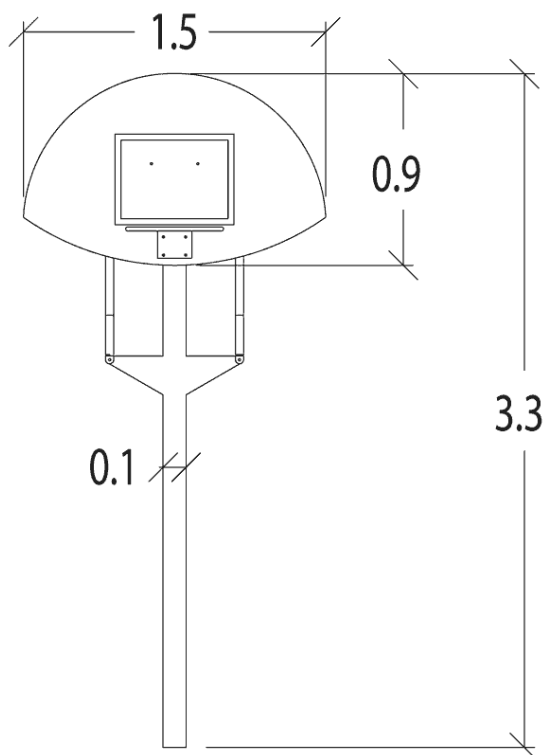

Panneau en contreplaqué de 22 mm d'épaisseur revêtu de peinture polyuréthane. Ossature en tube galvanisé.

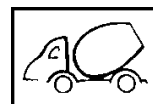

INSTALLATION



0.4m³



2

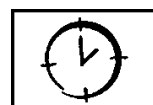

01h00

INFOS DIVERSES



10 joueurs

CERTIFICATIONS



Poids total = 101 kg

Elément le + lourd = 75 kg