



3+



20



1,8m



1 = 6m 2 = 5,39m 3 = 2,9m

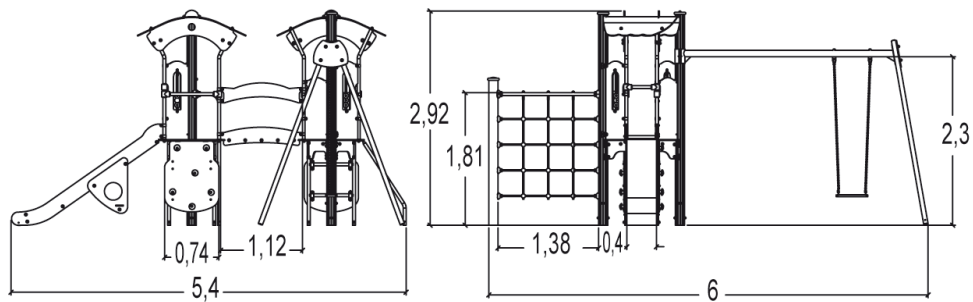

Fonctions ludiques : 6

escalader



x1

glisser



x1

se balancer



x1

grimper



x1

traverser



x1

se rencontrer /
fabuler



x1

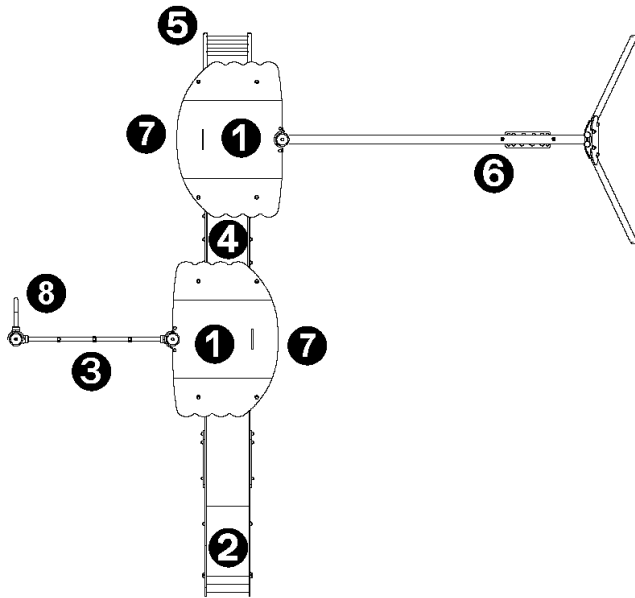

- ❶ Tour H : 1,17 m
- ❷ Toboggan Ht : 1,17 m
- ❸ Passerelle
- ❹ Echelle inclinée
- ❺ Portique
- ❻ Palissade
- ❼ Garde-corps poteau/tube
- ❽ Mur d'escalade

Installation de l'équipement

Zone d'impact : Surface de sol minimale requise

- Zone d'impact
- Espace libre

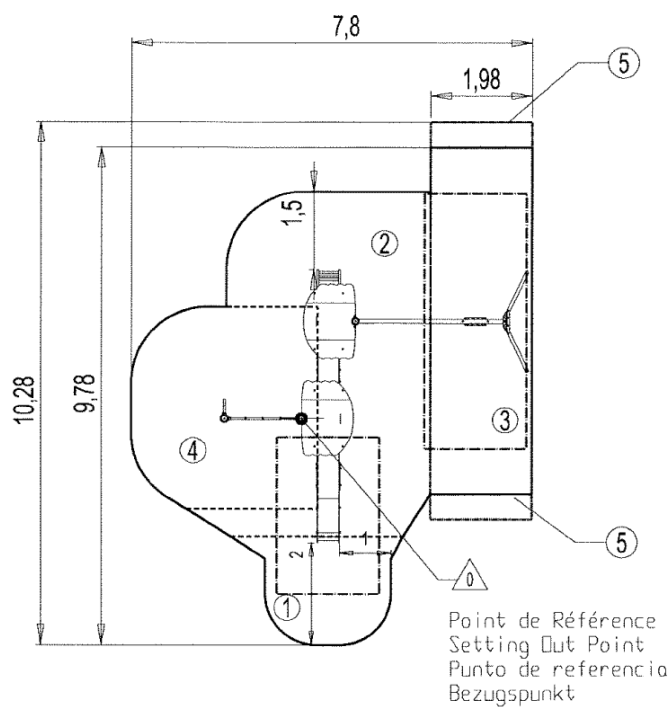

1	1m	5m ²
2	1,17m	19,5m ²
3	1,4m	13,5m ²
4	1,8m	13,5m ²
5	<0,6m	2m ²



2



20h00



0.31m³



51.5m²



281kg



-

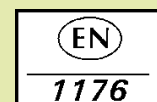

Proludic

0000-00-00