



3+



15



2,6m



1 = 2,83m 2 = 5,15m 3 = 3,22m

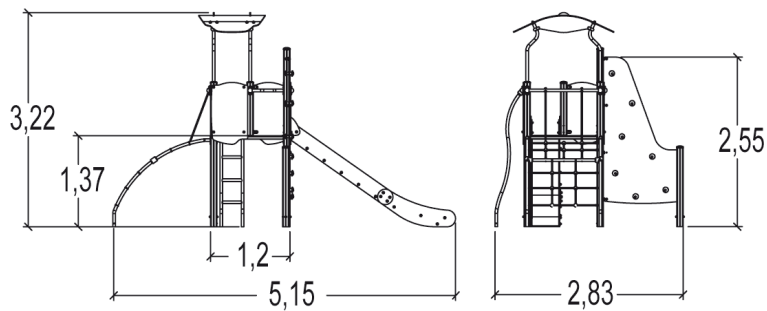
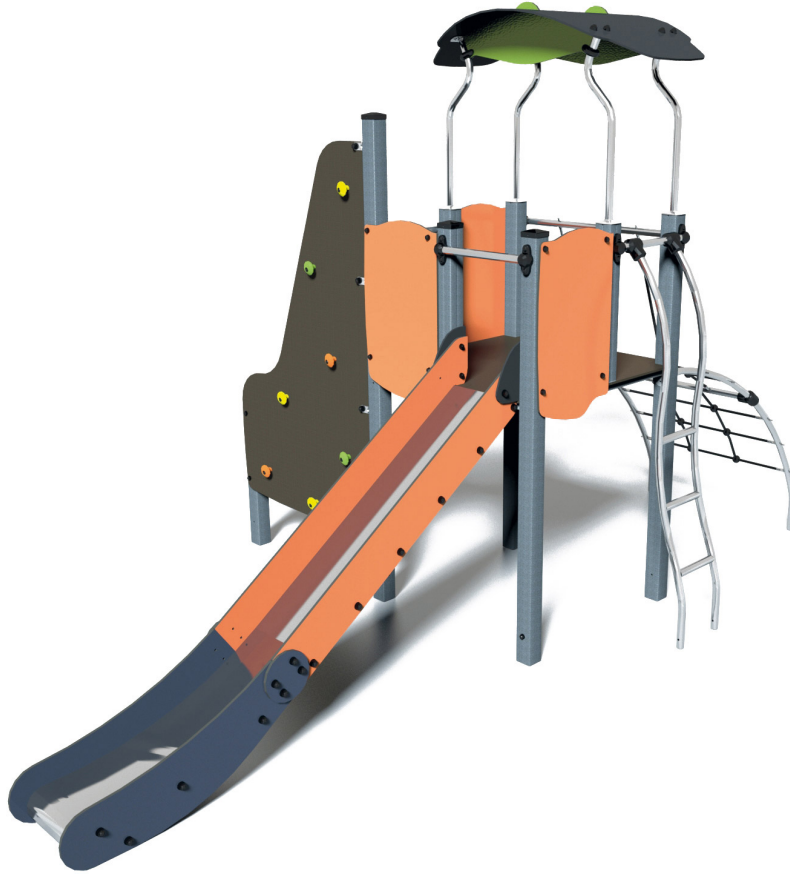

Fonctions ludiques : 14

escalader



x2

fabuler



x1

glisser



x2

se rencontrer



x2

manipuler



x1

s'abriter



x1

réfléchir

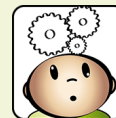

x1

stimulation tactile



x1

stimulation visuelle



x1

grimper



x2

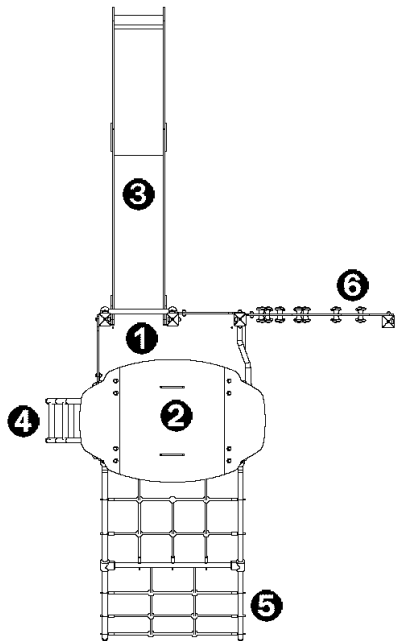

- ① Plate-forme carrée Ht : 1,37 m
- ② Toit
- ③ Toboggan H : 1,37 m
- ④ Echelle cintrée H : 1,37 m
- ⑤ Filet courbe H : 1,37 m
- ⑥ Mur d'escalade

Installation de l'équipement

Zone d'impact : Surface de sol minimale requise

- Zone d'impact
- Espace libre

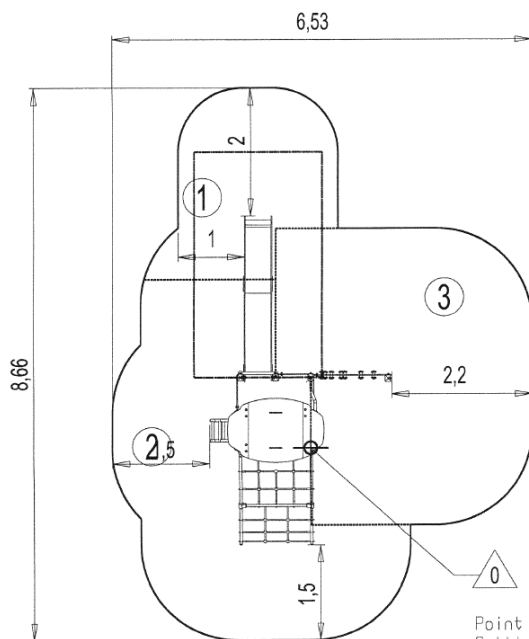

Point de Référence
Setting Out Point
Punto de referencia
Bezugspunkt
Referentiepunt

1	1m	7m ²
2	1,37m	17m ²
3	2,6m	17m ²



2



10h00



0.3m³



41m²



351kg



33kg

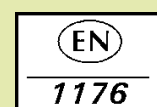

Proludic

2015-06-30